

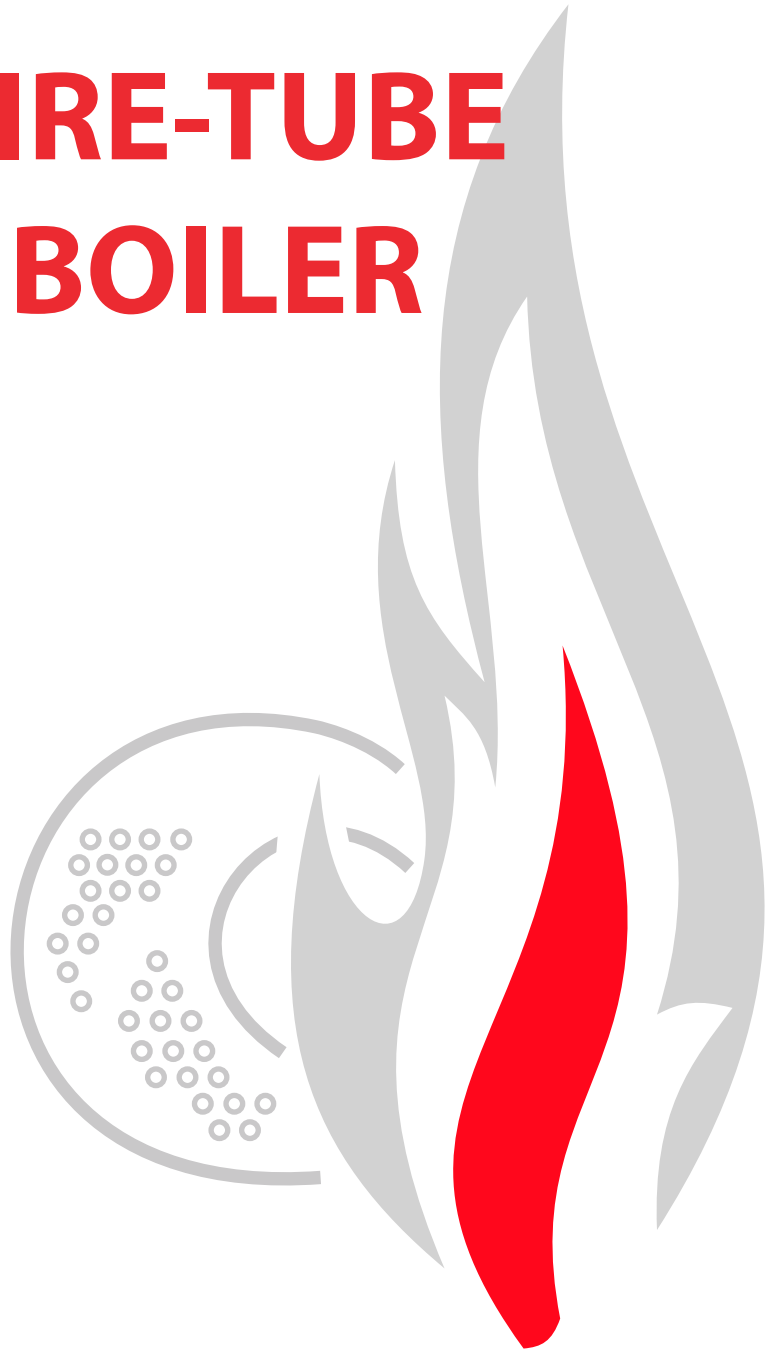

FIRE-TUBE BOILER



AFTERSALES SUPPORT | BIOMASS | ELECTRIC STEAM BOILER | EPC MANAGEMENT
FIRE-TUBE BOILER | IIoT SYSTEMS | MANUFACTURING | QUICK STEAM BOILER
PROJECT MANAGEMENT | THERMAL OIL HEATERS | TRAINING CENTER | WATERTUBE SYSTEMS

FIRE-TUBE BOILERS WITH FULLY WET-BACK DESIGN

EFFICIENT 3 PASSES.
FLEXIBLE FUEL.
VERSATILE DESIGN.

PROVEN SOLUTIONS

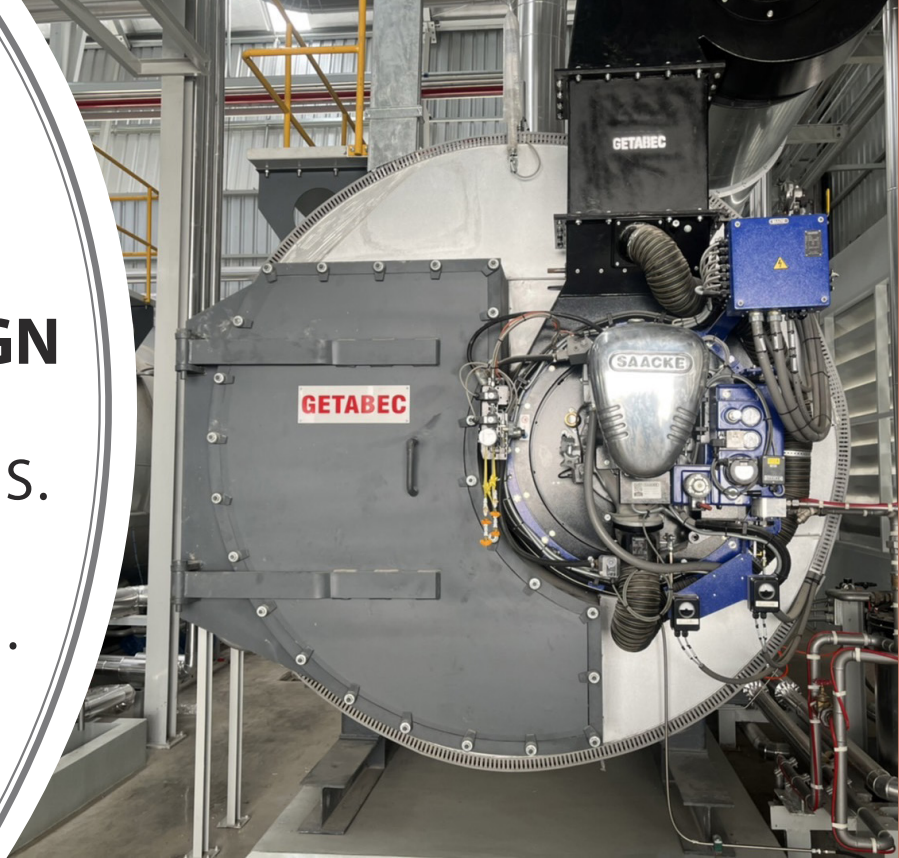

STABLE & EFFICIENT FIRE-TUBE BOILERS

Experience the cost savings with our superior high-performance boilers utilising optimized **three pass fire-tube** system.

Our innovative design maximizes energy transfer through multiple passes, ensuring **optimal efficiency** and **reducing fuel** consumption.

Our boilers use the state-of-the-art fully WET-BACK design which allows **maximum heat transfer** unobstructed by any refractory. This in turn leads to higher reliability and lower maintenance costs.

BENEFITS

- > Stable Steam Supply
- > Simple Maintenance
- > Customizable
- > 0.5-55 tph, 3-30 barg

ACCELERATE YOUR BUSINESS TODAY

As your **trusted supplier**, we are committed to delivering exceptional fire-tube boilers to meet your unique business needs.

Experience the **value of partnering** with us and take your company to new heights with our top-of-the-line system.

Our commitment extends to **full support** for the lifetime of your system.



Lifetime Support



Improve Production



24/7 On-call Support

BOOST EFFICIENCY, EMBRACE DURABILITY

HIGH EFFICIENCY, RELIABLE OPERATIONS, FLEXIBLE FUEL

The three-pass design of traditional fire-tube boilers offers a distinct advantage in heat transfer efficiency. GETABEC's unique inside arranged 100% water-cooled flue gas reversing chamber in the state-of-the-art WET-BACK design guarantees ideal heat transfer unobstructed by any refractory allowing for maximum boiler efficiency.

The multi-pass configuration ensures balanced heat distribution and reduced stress on the boiler components. The longer residence time of the flue gases within the boiler enhances heat absorption and reduces thermal shock. This robust design contributes to the boiler's durability, longevity, and reliable operation, minimizing downtime and maintenance costs.

Fire-tube boilers with a three-pass design offer versatility in burner options, accommodating a variety of fuel types. This flexibility allows operations in different industries providing quick response to load changes, ensuring stable and responsive steam production. Adaptability is ideal for various operational requirements and enhances overall system efficiency.



PARTNER FOR LIFE

GETABEC's comprehensive support extends across the lifetime of your system and operations. From design and manufacturing to installation and after-sales support, all stages are rigorously controlled in-house, ensuring optimal quality.

Trust in our industry-leading expertise, backed by International certifications, for a system that delivers both unmatched performance and enduring durability. When choosing GETABEC, you're investing in reliability and efficiency that stands the test of time.

COMPATIBLE WITH ANY FUEL

OIL & GAS.
HYDROGEN.
BIOGAS.

PROVEN EXPERIENCE





SINGLE FLAME TUBE



DOUBLE FLAME TUBE

GETABEC

IN-HOUSE LIFETIME SERVICES

DESIGN & ENGINEERING



MANUFACTURING



INSTALLATION



AFTERSALES & UPGRADES



DESIGN SPECIFICATIONS

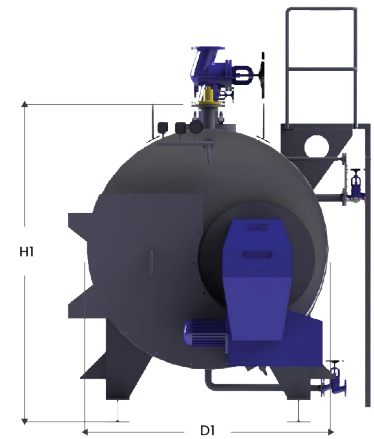
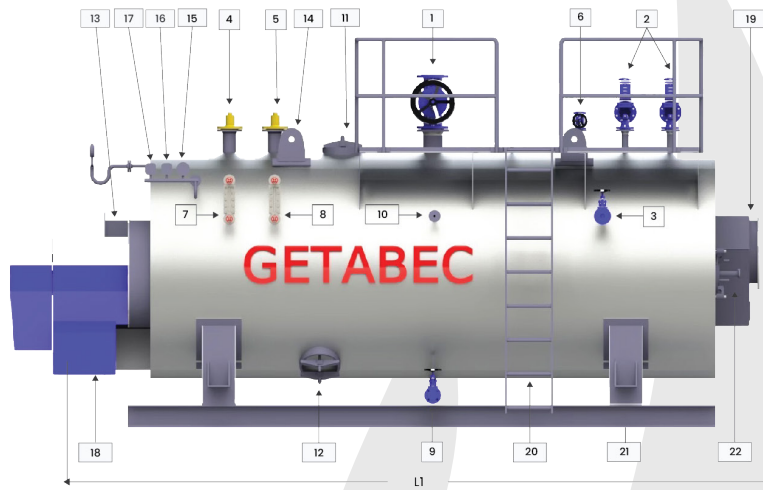

1	Main Steam Valve	12	Head Hole
2	Safety Valve	13	Front Reversal Chamber
3	Feed Water Valve	14	Lifting Lug
4	Water Level Control	15	Pressure Gauge
5	Water Level Alarm	16	Pressure Switch
6	Vent Valve	17	Pressure Transmitter
7	Water Level Indicator	18	Burner
8	Water Level Indicator (Option)	19	Flue Gas Outlet
9	Bottom Blowdown Valve	20	Platform and Ladder
10	Surface Blowdown Valve	21	Base Frame
11	Manhole	22	Flame Inspection Hole

MODEL HDO	1000	1600	2000	2500	3200	4000	5000	6000	8000	10000	12000	15000
D1 (mm)	1500	1700	1750	1750	1000	2000	2000	2200	2500	2600	2900	3000
L1 (mm)	2951	3651	3411	3661	4163	4714	5714	5789	6435	6335	6717	6881
H1 (mm)	1890	2060	2100	2100	2250	2455	2455	2650	2950	3062	3325	3500

The dimensions of the boiler include the insulation (100 mm thick) and for a boiler with a maximum design pressure of 10 barg only

P&ID STANDARD DESIGN

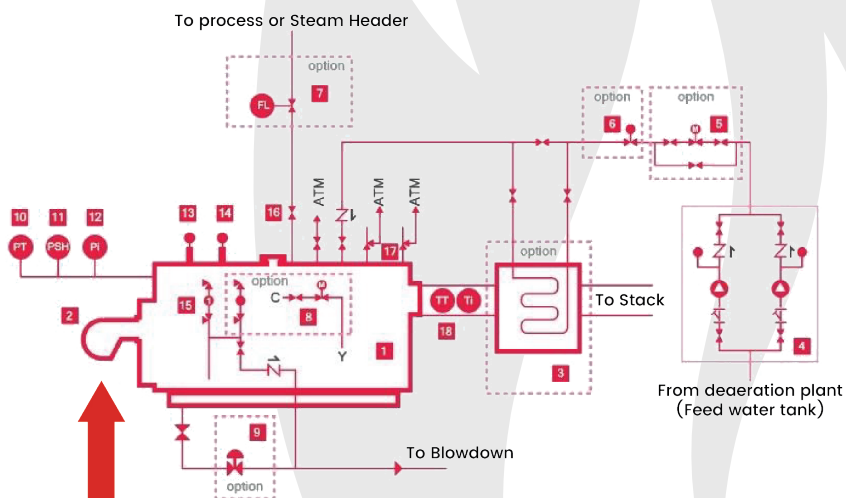

- Heavy Oil
- CKB
- Natural gas
- Diesel
- LPG
- Biogas
- Hydrogen

1	Steam Boiler
2	Burner
3	Economizer (Option)
4	Feed Water Pump Set
5	Feed Modulating Control (Option)
6	Water Flow Meter (Option)
7	Steam Flow Meter (Option)
8	Surface Blow Down (Option)
9	Auto Bottom Blow Down (Option)
10	Pressure Transducer
11	Pressure Limiter
12	Pressure Gauge
13	Level Sensor and Low Level 1
14	Low Level 2
15	Level Indicator
16	Main Steam Valve
17	Safety Valve 1,2
18	Temperature Sensor for Flue Gas Limiter

=YOUR RELIABLE PARTNER
BUSINESS SUCCESS 

AUTHORIZED MANUFACTURER



Lloyd's Register
LRQA



GO PAPERLESS
SCAN ME TO GO
TO CATALOG

GETABEC PUBLIC COMPANY LIMITED

335/7 Srinakarin Road, Nongbon,
Pravej, Bangkok 10250.

Tel: +66 (0) 2 366 0400 - 7

Fax : +66 (0) 2 366 0413

Website : www.getabecboiler.com

Email : sales@getabecboiler.com



GO PAPERLESS
SCAN ME TO GO
TO WEBSITE